

## Blueline HFM (Hand FLAKKOTING Machine)

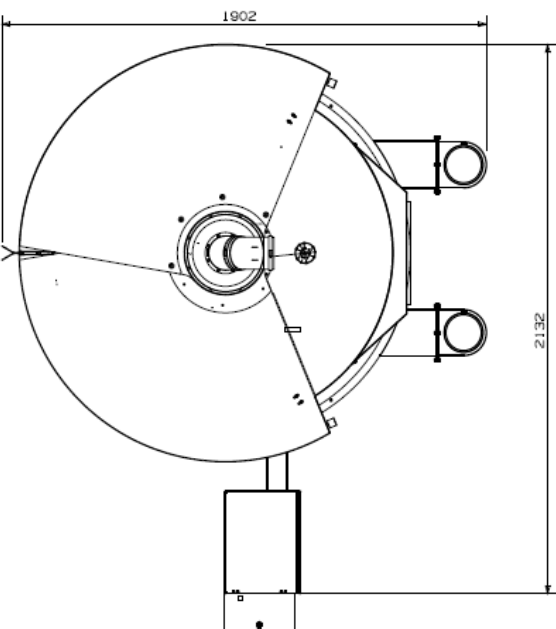

Technical information LEM	
Length	2500 mm
Width	1950 mm
Height	2500 mm
Weight	3000 Kg
FLAKKOTIER-Power	4 kW
Connection-Power (depending on equipment)	ca. 6 kW
FLAKKO units	1
Tools per unit	1
Processing width	180 mm
Processing height	250 mm
Table pitch circle	600 mm
Table external diameter	800 mm
Feed	0.5 – 6.0 m/min

**Layout**

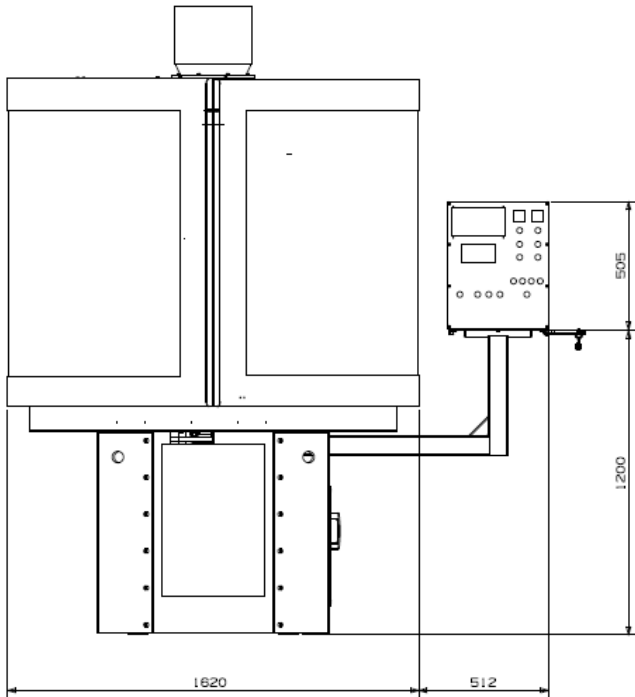
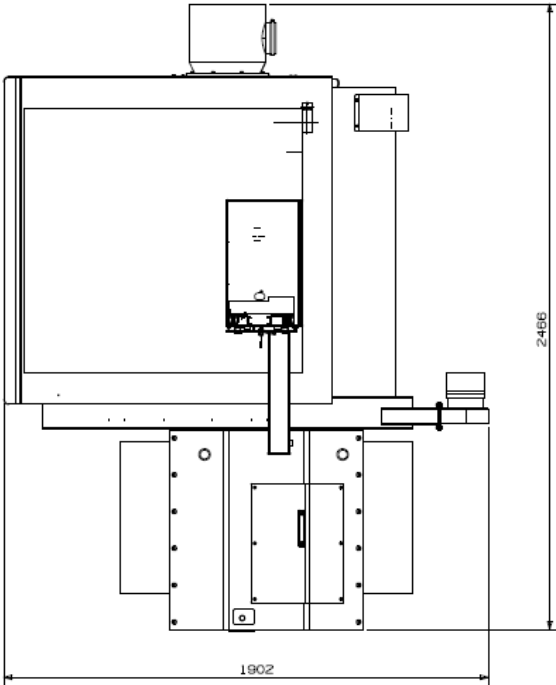

### **Typical applications:**

Edge preparation of all kinds of cutting tools with appropriate mountings and turning mechanisms, e.g. cylindrical milling cutters, saw blades up to diameter of 380 mm, shank-type tools, indexable inserts and bandsaw coils up to diameter of 750 mm.

**Delivery period:** approx. 6 months

**Price segment:** Available on request

### **Customer benefits:**

- Customer can quickly produce preparations or polished finishes himself
- Machine can also be rented
- Although extremely easy to use, the customer is assisted in the FLAKKOTING process with the built-in laptop computer
- Acoustic emission system (AES) supports probing by the FLAKKOTING tool
- Return on investment for some customers within the first year of operation
- Machine can be operated for dry machining, optionally also for wet machining
- Low operating and maintenance costs
- FLAKKOTING tool database
- Customer workpiece database

### **Optional adaptations**

- Optionally also available with "Wet" fitting
- Workpiece mounting adapted to customer needs
- Extraction system

08.07.2015, ako