

Redline RTK (Rund Tisch Kontinuierlich)

(Continuous Round Table)



Technical information RTK	
Length	4100 mm
Width	2550 mm
Height	3300 mm
Weight	6500 Kg
FLAKKOTIER-Power	11 kW
Connection-Power (depending on equipment)	ca. 20 kW
FLAKKO units	1
Tools per unit	3
FLAKKO tool diameter	230 mm
Processing width (table ring width)	300 mm
Processing height	100 mm
Table outside diameter (usable)	1200 mm
Feed	0.2 – 10.0 m/min
Loading and unloading method	With crane or special handling
Processing method	Wet or dry

Layout

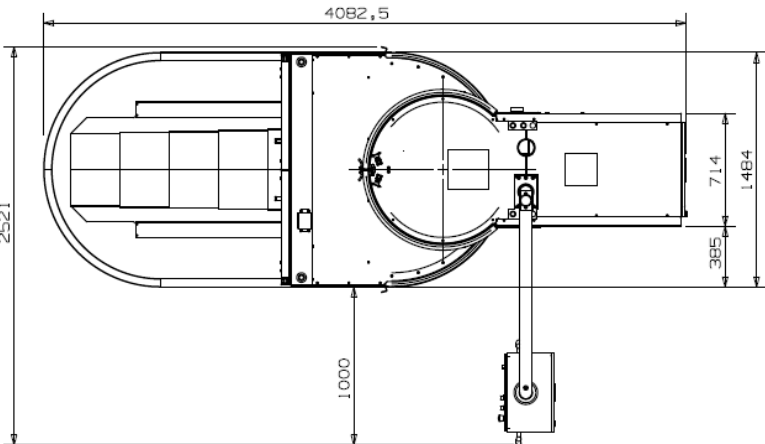
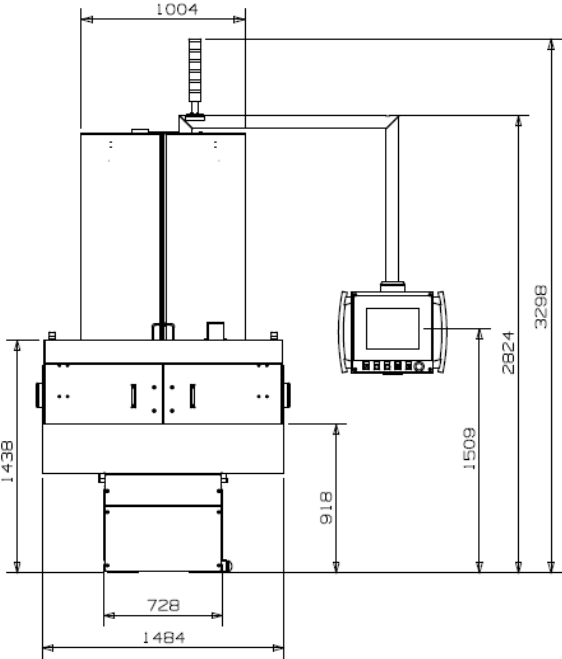
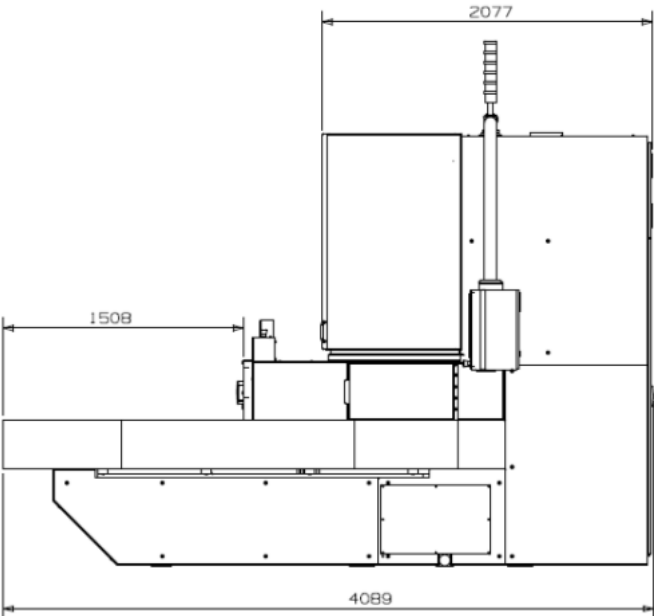

Typical applications:

Edge preparation of bandsaw coils up to diameter of 1200 mm, heavy-duty cylindrical milling cutters or similar workpieces in appropriate holders or turning mechanisms. Linear sliding round table for loading by crane.

Delivery time: 10 to 12 months

Price segment: Available on request

Customer benefits:

- Machine can be readily automated, especially for bandsaw coils
- Central and ergonomic touchscreen operation for all controls and information
- Return on investment for some customers after 1-2 years of operation
- Machine can be operated for wet machining, optionally also for dry machining
- Low operating and maintenance costs
- FLAKKOTING tool database
- Customer workpiece database

Customised adaptations (*examples*)

- Process material pumping station with vapour extraction as system extension
- FLAKKO power unit with program-controlled spindle stroke adjustment
- RFID tool monitoring system
- Dust extraction system (dry machining)
- Process material filtering system

08.07.2015, ako